

Original Scientific paper
UDK 656.1:711.4]:628.1/3
DOI: 10.7251/afts.2020.1223.053B
COBISS.RS-ID 129655297

ANALYSIS BANDWIDTH DRAIN ON CITY ROAD

Bašić Zahid¹, Galamić Anadel²

¹University of Tuzla, Faculty of Mining, Geology and Civil Engineering, Bosnia and Herzegovina,
e-mail: zahid.basic@untz.ba

²University of Tuzla, Faculty of Mining, Geology and Civil Engineering, „GPP Banovići“ ltd.
Banovići, Bosnia and Herzegovina

SUMMARY

Drainage of surface water from the pavement structure is an important parameter for preserving the designed period and safety during the operation of the pavement structure. The paper presents research on the relationship between the efficiency of drains depending on the cross slope. When the correct selection of transverse slopes and the collection of rain runoff from the catchment area of the road, the safety of the operating conditions itself increases.

By changing the transverse slope, the parameters in terms of water runoff speed and drain efficiency also change. During the analysis, this paper also took into account the hydrological parameters for the site where the section in question is located.

The analysis in this paper aims to show how the correct selection of cross slopes of pavement structures can be of key importance for the efficiency of the drain, and thus the efficient drainage of surface water from the pavement structure.

Keywords: *rain, runoff, cross slope, efficiency, drainage*

INTRODUCTION

Efficient road drainage is very important for ensuring the stability of the lower and upper road machinery, as well as for comfort and safety under operating conditions. [1] The basic task for fulfilling these conditions is that all forms of water are kept under constant control and drained by the shortest route into permanent or occasional natural watercourses. Proper selection of the geometric relations of the upper machine and the drainage system achieves faster drainage, and in this regard increases the degree of traffic safety.

In order to view the results of the research of surface water drainage from the road with regard to the efficiency of the drain, the section of the road in the length of $L = 100.0$ m was treated in the paper. The initial transverse slope is 1.5% and the final 2.5%. Cross slopes were increased from the initial to the largest with a step $h = 0.25$. For the purposes of the research in this paper, the catchment area of the pavement structure was determined, and the time of basin concentration was calculated for each transverse slope separately. [2,3]

DEFINITION PARAMETERS

The water from the upper surface of the road is to be drained through drains and through drainage rigs into the collecting pipe leading to the main drain receptacle. [4] The hydraulic calculation contains the necessary information on the choice of precipitation intensity, the frequency of the spill, the coefficient and the time runoff. The hydraulic calculation is used to disposition the drainage arrangement and drainage capacity. [5]

Appropriate drainage system achieves efficient and rapid removal of atmospheric water from the carriageway, ie fixed carriageways (in particular, water from the carriageway), and from the surrounding areas from which water flows along the way (water from other surfaces).

Therefore, two ways of drainage differ:

- scattered (to the wider area)
- point (at a specific place)

If the drainage of atmospheric water from the carriageway is carried out at a specific location, the water is not allowed to be carried directly into standing surface water, water intended for the preparation of drinking water or ground water. [6] If the criteria for permissible levels of water contamination have exceeded, appropriate precautionary measures should be taken to keep water in carriageway and take its exit from the carriageway as drainage at a given location [7,8].

These precautionary measures depend on the type of pollution that may be permanent or extraordinary. Permanent pollution is primarily related to intermittent spillage of petroleum products, as well as to the remnants of rubber, brake linings and pouring salts that cause rain. Said contamination can be controlled by releasing water in the proper retention of the structure. Extreme pollution, which may be due to the release of hazardous substances, may have catastrophic consequences on groundwater and the wider area. [9, 10]

The following conditions are relevant for scattered drainage:

- roads crossing areas characterized by grain and cracking structures, if the daily average of passenger vehicle units during the year does not exceed 12,000
- roads crossing the limestone characteristics if the daily average of passenger vehicle units during the year does not exceed 6,000
- the roads which cross the areas in which materials are with a bandwidth of up to $\leq 10^{-6}$ m / s, if the daily average of passenger vehicles during the year does not exceed 40,000
- roads where atmospheric water is discharged directly into liquid or standing water if the daily average of passenger vehicle units does not exceed 12,000 during the year

In all other cases, it is necessary to foresee a drainage method at a specific location, for the purpose of draining atmospheric waters. [11]

Solution to the drainage is preceded by previous hydrological measurements and surveys, and good knowledge of hydrology and hydraulics are prerequisites for optimal, economical and efficient solutions.

For the drainage of significant construction, knowledge of hydrometeorological data such as: intensity, height, duration and precipitation frequency, temperature oscillations, duration and depth of penetration of the frost.

HYDROLOGICAL CALCULATION

The amount of rainwater in direct dependence on the intensity of the precipitation, the size, the type and the inclination of the surface from which the runoff is carried out. The calculation of the quantity is based on the adopted rainfall values from IDR curves for RS Tuzla, for a 5 minute rainfall and a 5 year return period, Figure 1. [12]

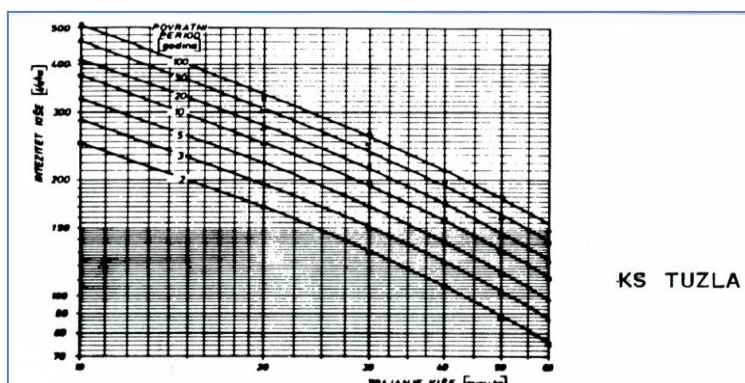

Figure 1. The graph of the dependency of the "intensity-duration-return period" according to the peak method

The following table shows the calculation of time of concentration of the watershed (traffic areas) and the calculation of the relevant amounts of total drainage of precipitation water from the same areas, Table 1.

Table 1: Calculation of the time of concentrations of the watershed section $l = 100,00$ m

Cross slopes	C	L (m)	S sr. (m/m)	tc. calc. (min)	tc. adopted (min)
Cross slope 1.5 %	0.85	100	0.015	7.09	7.50
Cross slope 1.75 %	0.85	100	0.018	6.73	7.00
Cross slope 2.0 %	0.85	100	0.020	6.44	6.50
Cross slope 2.25 %	0.85	100	0.023	6.19	6.30
Cross slope 2.50 %	0.85	100	0.025	5.98	6.00

HIDRAULIC CALCULATION

In the first phase of the hydraulic calculation, all the parameters of the rainfall collection from the coniferous surface area of the conveyor section in $L = 100.0$ m, with the assumed gap of 20.0 m.

Based on the calculation of the parameters of the rainfall from the watershed area and the obtaining of the relevant amount of drifts and the velocity of the flow, the efficiency of the drain on the section of the road was determined (Table 2), (Figure 2). [13]

Table 2: Runoff speed and drainage efficiency in relation to cross slope

Cross slope	v_a (m/s)	E
1,50%	0,703473	0,661607
1,75%	0,732922	0,698307
2,00%	0,801418	0,682957
2,25%	0,783218	0,757154
2,50%	0,805186	0,780935

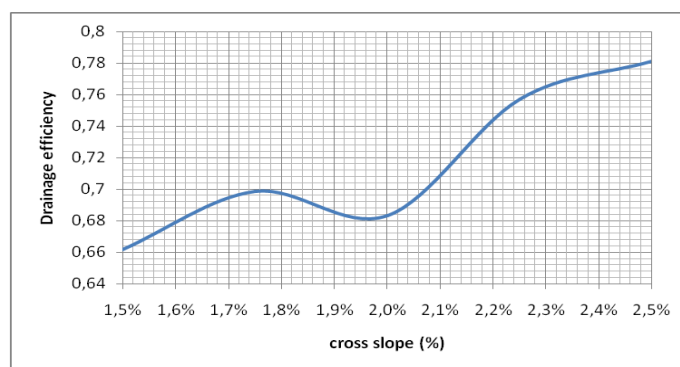

Figure 2. Function of drainage efficiency in relation to the cross slope of the pavement

REGRESSION AND CORRELATION

In the software package 3B STAT, a mathematical calculation of regression and correlation of cross slopes of the pavement structure and drain efficiency was performed, and it was also shown that the simple correlation coefficient is statistically significant, which proves their mutual linear dependence. (Table 3). [14]

Table 3: Results of statistical analysis

01.08.2020 20:46 Analysis Number: 1				
Simple regression				
Explanatory variable X = cross slope %			Dependent variable Y = Drain efficiency	
Drain efficiency = 0.4782 + 0.119 * cross slope %				
Parameter	Rating	Stand. Estimation error	t-value	p-value
section	0,4782	0,05590	8,5474	0,0034
slope	0,119	0,02751	4,3201	0,0229
Determination coefficient $r^2 = 0,8615$ (86,1518 %)				
Standard regression error $s = (0,0218)$				
Comment:				
The grade of the section is significant at the level of 0.05				
The slope estimate is significant at the 0.05 level. Variable Transverse drop% affects the variable Drain efficiency				
01.08.2020 20:47 Analysis Number: 2				
Pearson's simple correlation coefficient r				
Varijables				
X:	Cross slope %			
Y:	Drain efficiency			
r:	0,9282			
TESTING				
Standard error Simple correlation coefficient			T-test statistics	P
0,2149			4,3201	0,0228544
H ₀ :	There is NO linear correlation in the base set			
H ₁ :	There is a linear correlation in the basic set			
Conclusion:				
When testing the null hypothesis that there is no linear correlation in the basic set, the obtained p-value of 0.0229 indicates that				
in the basic set there is a linear relationship at the significance level of 0.05 because the p-value is <0.05.				
We conclude that the simple correlation coefficient r is statistically significant				

CALCULATION OF THE DRAINAGE CAPACITY

The values of hydraulic calculation for the treated cross slopes are shown in the next table. (Table 4).

Table 4: The values of hydraulic calculation for the treated cross slopes

Cross slope	Q (l/s)	Q _w (l/s)	Q _s (l/s)	Q _i (l/s)	Q _b (l/s)
1.50%	17.26953	10.41561	6.853919	11.57059	5.698945
1.75%	17.44109	11.23651	6.204582	11.68553	5.75556
2.00%	21.81661	14.05072	7.765893	14.61713	7.199482
2.25%	17.69009	12.61615	5.07394	11.85236	5.83773
2.50%	17.78387	13.20145	4.582421	11.91519	5.868677

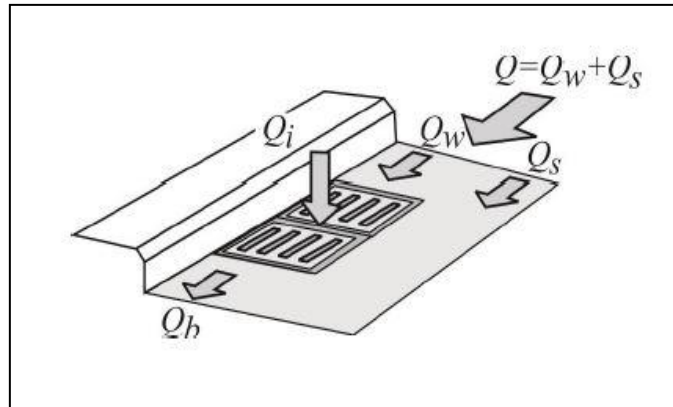

Figure 3: Components flow to the drain

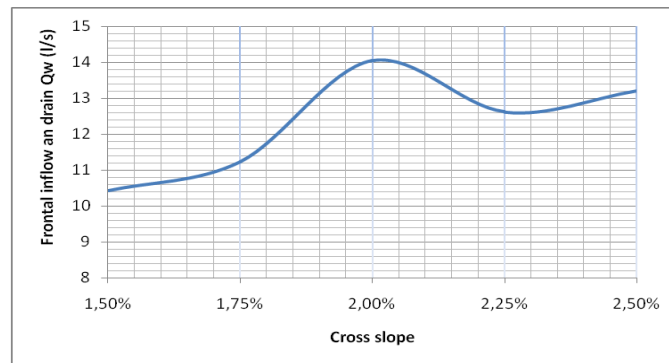

Figure 4. The function of the frontal inflow drain (Q_w) to the cross slope

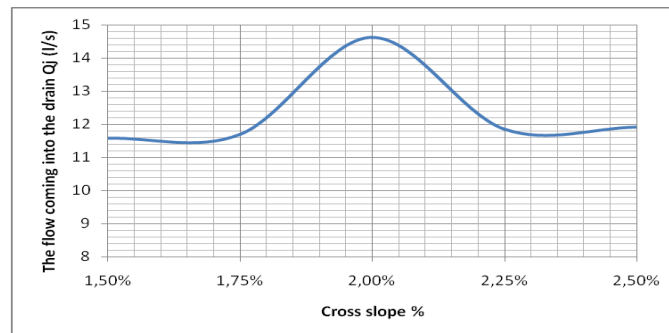

Figure 5. Function whose flow the drain (Q_i) compared to the cross slope

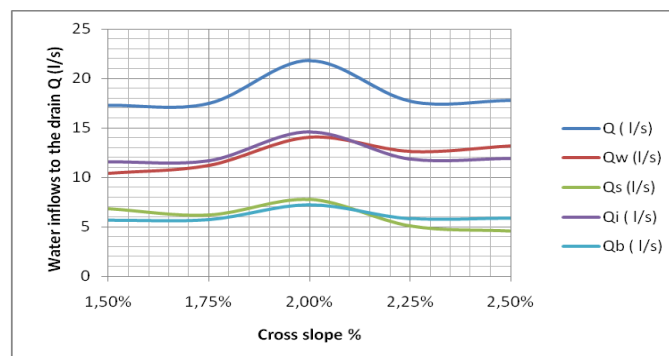

Figure 6. Functions of water inflow into the drain and its components in relation to the cross slope.

CONCLUSIONS

The conducted research in this paper deals with the topic of the influence of cross slopes of pavement structures on the hydraulic calculation of drainage.

At a specific location, for which influential parameters were made, the calculation of runoff parameters from the catchment area of the road in the length of $l = 100.0$ m and width $b = 11.5$ m was performed.

Based on the relevant parameters of rain runoff and the amount of precipitation, the efficiency of the drain was determined at the assumed distance of $l = 20.0$ m.

It can be seen from Figure 2 that by increasing the slope of the cross section of the pavement structure, the efficiency of the drain also increases.

For the transverse slopes of the pavement structure of 2.25% and 2.50%, it can be seen that the efficiency of the drain is used more than 67%, which is the lower limit of the efficiency of the drain. For economic reasons, the distance between the drains during the observed rainy season and for the conditions used in this study may increase. To determine the distance of the drain, it is necessary to perform the calculation in the way presented in this study.

The work represents a good basis for further research in terms of proper selection of transverse tilt of pavement structures in order to efficiently drain the surface water from the pavement and to preserve the planned period and the exploitation conditions of the road itself.

(Received August 2020, accepted August 2020)

REFERENCES

- [1] Stanić, M. (2018). Rainwater drainage, University of Belgrade, Faculty of Civil Engineering, Serbia. [Serbian language]
- [2] Bašić, Z. (2014). Roads, publishing house OFF-SET Tuzla, Bosnia and Herzegovina. [Bosnian language]
- [3] Hrelja, H. (2007). Engineering Hydrology, University of Sarajevo, Bosnia and Herzegovina. [Bosnian language]
- [4] Despotović, J. (2009). Surface runoff of rainwater and storm sewers, University of Belgrade, Faculty of Civil Engineering, Serbia. [Serbian language]
- [5] Hvitved-Jacobsen T., Vollertsen J., Nielsen A. 2010. Urban and Highway Stormwater Pollution-concepts and Engineering. CRC Press. Taylor&Francis Group, Boca Raton, FL, USA.
- [6] U.S. Department of Transportation, Federal Highway Administration, 2001. Hydraulic Engineering Circular No. 22, Second Edition, Urban Drainage Design Manual
- [7] Guidelines for design, construction, maintenance and supervision of roads, (2005). Sarajevo/Banja Luka, Bosnia and Herzegovina. [Bosnian language] [Serbian language]
- [8] Manual for road design in the Republic of Serbia, drainage system, (2011). Belgrade, Serbia. [Serbian language]
- [9] Biondi S., Sambo F., Bottega P. (2015). Stormwater runoff: impact, risk analysis and emergency management on an Italian highway, Asia Pacific Stormwater conference, 20-22 May, Auckland, New Zealand. [English language]
- [10] Metcalf&Eddy, 2002. Wastewater Engineering: Treatment and Reuse, 4th edition, McGraw Hill Inc., NY, USA. [English language]
- [11] T.N. Debo and A.J. Reese, 2003. Municipal Stormwater Management, 2nd ed. Lewis Publishers, New York, USA. [English language]
- [12] Suljić, N. (2018). Hidrotehnika- solved tasks and theoretical bases, publishing house OFF-SET Tuzla, Bosnia and Herzegovina. [Bosnian language]
- [13] Galamić A., Tokić M., Hrnjadović J, (2019). The influence of cross slope on hydraulic calculation of drainage pavements , Modern achievements in construction, Subotica 23-24. April 2019. Serbia. [Serbian language]
- [14] Nurkanović, Z., Demirović- Garić, M. (2016). Selected Chapters in Mathematics, PrintCom Tuzla Publishing House, Tuzla, Bosnia and Herzegovina. [Bosnian language]